

## DESCRIPTION

Pushbuttons and signaling units Series PBA, made in Aluminum light alloy (Mg+Ti+Zirconium < 6%) with stainless steel external bolts, are available with control and signaling units covered by component certificate INERIS 14 ATEX 9016U e IECEx IEC 14.0055U ( or other control and signaling unit with equivalent certification). Local control stations are available in four different sizes: pushbuttons equipped with one ("PB 1"), two ("PB 2"), three ("PB 3") and four ("PB 4") units. In addition, versions of pushbutton series PB in Stainless Steel AISI 316L (letter "S" is added to code - "PBS"), Cast Iron (letter "C" is added to code - "PBC") or Nickel plated brass (letter B is added to code - "PBB") are available. For series PBA the standard external coating is grey color RAL 7000. Other colors are available upon request by customer.

For series PBB, PBC and PBS normally no external coating is used (only on customer demand). The thickness of the external paint must be < 0.2 mm for gas groups IIC-IIB+H2 and < 2 mm for gas group IIB.

Pushbuttons and signaling units series PB are designed and manufactured according the following European and International Standards for electrical apparatus:

IEC 60079-0	: 2017	EN IEC 60079-0	: 2018
IEC 60079-1	: 2014-06	EN 60079-1	: 2014
IEC 60079-31	: 2013	EN 60079-31	: 2014

The respect of the Essential Health and Safety Requirements of 2014/34/EU Directive, of IECEx Scheme Rules, of IECEx 02 and Operational Documents as amended has been assured by compliance to previous Standards.

**PB1**

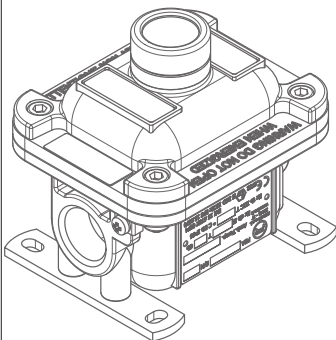

**PB2**

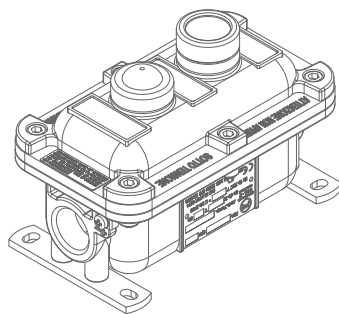

**PB3**

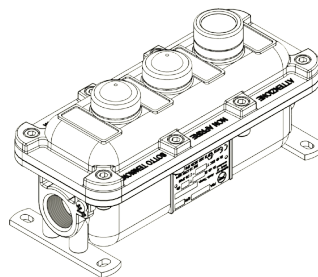

**PB4**

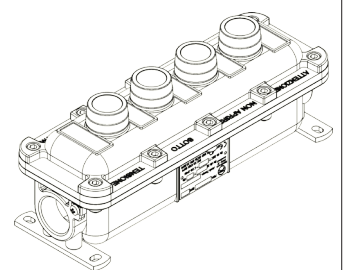

The respect of the Essential Health and Safety Requirements of 2014/34/EU Directive, of IECEx Scheme Rules, of IECEx 02 and Operational Documents as amended has been assured by compliance to previous Standards.



# RIBCO

## EXPLOSION PROOF EQUIPMENT

Via dei Mille, 12 - 20061 - ITALY Carugate (MI)  
www.ribco.it - info@ribco.it



**SAFETY NOTE**  
Pushbuttons and signalling units  
series PB

IS-PB-EN  
Rev. 2 - 23/09/2020  
Pag. 2 / 4

Tab 1

ELECTRICAL CHARACTERISTICS					
	Maximum voltage		Standard current	Maximum power	Standard frequency
	V ac	V dc	A	W	Hz
Pilot light with socket BA9s, BA15s	240	240/24	10	5	50/60
Other units	690	440	10	0.5	50/60

### MARKING FOR SERIES PBA

RIBCO  
I-20061-CARUGATE (MI)  
Code Article  
IECEX EPS 15.0070  
BVI ATEX 0074  
Serial number  
 0722   
 Ex db IIC ( or IIB or IIB+H2) (\*) T6 ÷ T4 (\*\*) Gb  
 Ex tb IIIC T85°C ÷ T135°C (\*\*) Db IP65/66  
 A.T. -20°C ÷ +40°C  
 (Max. -50°C ÷ +80°C)

### MARKING FOR SERIES PBS/PBB/PBC

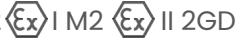
RIBCO  
I-20061-CARUGATE (MI)  
Code Article  
IECEX EPS 15.0070  
BVI ATEX 0074  
Serial number  
 0722   
 Ex db I Mb  
 Ex db IIC ( or IIB or IIB+H2) (\*) T6 ÷ T4 (\*\*) Gb  
 Ex tb IIIC T85°C ÷ T135°C (\*\*) Db IP65/66  
 A.T. -20°C ÷ +40°C  
 (Max. -50°C ÷ +80°C)

(\*) See Tab 4 / (\*\*) See Tab 5

WARNING - DO NOT OPEN WHEN ENERGIZED.

WARNING - GREASE COATING ON PLAIN JOINT MUST BE RESTORED BEFORE CLOSURE AND ONLY STAINLESS STEEL SCREWS QUALITY A2-70 or A4-70 AND CABLES SUITABLE WITH INDICATED TEMPERATURE CLASS MUST BE USED.



## EQUIPMENT IDENTIFICATION

a + b + c example PBA 25 3

### (a) MODEL

Tab 2

CODE	DESCRIPTION
PBA	Aluminium light alloy ALSi12
PBS	Stainless Steel AISI 316L
PBC	Cast Iron
PBB	Nickel plated brass

### (b) DIMENSION OF CABLE ENTRY

Available the following threading:

- Taper threading: ANSI/ASME B1.20.1
- Cylindrical threading: ISO METRIC ISO 262 - ISO 965 - 1,2,3

Tab 3

CODE	DESCRIPTION	CODE	DESCRIPTION
2	3/4" NPT	25	M25x1.5
3	1" NPT	32	M32x1.5

In case there will be different dimensions in the same box, in the marking will be use the letter "K" and a layout of the entries of the box, it will attached with the safety notes.

### (c) EQUIPMENT DIMENSION AND GAS GROUP

Tab 4

Model	PB1	PB2	PB3	PB4
Gas Group	IIC	IIC	IIB+H2	IIB+H2

Temperature class and maximum surface temperature

Tab 5

Installed bulb type / Max power	Temperature class		Max ambient temp. (A.T. max)
	GAS	DUST	
WITH INCANDESCENT / HALOGEN LAMPS	T6	T85°C	Up to +50°C
	T5	T100°C	+50°C < A.T. max ≤ +65°C
	T4	T135°C	+65°C < A.T. max ≤ +80°C
WITH LED LAMPS	T6	T85°C	Up to +60°C
	T5	T100°C	+60°C < A.T. max ≤ +80°C
COMMAND UNITS ONLY	T6	T85°C	Up to +80°C



# RIBCO

EXPLOSION PROOF EQUIPMENT

Via dei Mille, 12 - 20061 - ITALY Carugate (MI)  
www.ribco.it - info@ribco.it

## SAFETY NOTE

Pushbuttons and signalling units  
series PB

IS-PB-EN

Rev. 2 - 23/09/2020

Pag. 4 / 4

## INSTALLATION

### **Before installation read carefully all available technical specifications.**

- All pushbuttons and signaling units Series PB are electrical equipment for Group II, intended for use on surface plants. Pushbuttons and signaling units Series PBS, PBB and PBC, indeed, are electrical equipment for Group I and II, intended for use on mines susceptible to firedamp and/or on surface plants. Are also intended for use in classified areas called Zone 1 and/or zone 2 (according to EN 60079-10-1 Standard) and in classified areas called Zone 21 and/or zone 22 with presence of combustible dust (according to EN 60079-10-2 Standard).
- Pushbuttons and signaling units Series PB must be installed and maintained according to relevant Standards for electrical installations in hazardous areas classified for explosive gas and/or combustible dust atmospheres EN 60079-14 and EN 60079-17 (in their latest editions), or equivalent local National Standards.
- All apparatuses must be ground connected; devices have an appropriate external and internal screw and bracket indicating the right location for ground connection Use terminals and devices suitable, on each cast, against release and rotation.
- Supply pushbuttons with cable suitable for the relevant temperature class.
- Joint surfaces must not have been further on worked and/or covered by paint or dust.
- The degree of protection IP66 is guaranteed only if plain joint is treated with grease and if units on cover and accessories on cable entries are blocked with a thread locker product along the entire circumference and at least for one thread. The grease applied shall be of a type that does not harden because of ageing and does not contain an evaporating solvent. After each enclosure opening, the grease layer must be restored according to manufacturer's recommendations.

### **The installer and the user are always responsible of correspondence of plant location features with limits and general characteristics as above.**

Accessories used for cable entries must be certified according to ATEX or IECEx relevant standards and must be suitable with foreseen ambient temperature range and relevant degree of protection must be IP66.

In order to guarantee the IP66 protection a threadlocker must be used along the entire circumference and for at least one thread.

## MAINTENANCE AND REPAIR

- After each opening operation, grease must be restored on plan joint.
- User must regularly clean external surface of enclosure due to avoid any accumulation of dust on the surface (the maximum allowed thickness of dust is equal to 5 mm).
- All damaged parts for impact, accidental falls or simple wear, can be changed or repaired exclusively by manufacturer, expecting all particular authorizations of the same manufacturer as to guarantee protection mode and safety.
- Cable entries must have at least degree of protection IP65/66 and number of engaged threads must be greater than 5, with a minimum length of 8 mm.
- Grease coating on plane joint must be restored before closure. The grease applied shall be of a type that does not harden because of ageing and does not contain an evaporating solvent.
- Use only screws quality A2-70 or A4-70.